

## MSF ENGINEERING

**M.A. Darwish**

*Department of Mechanical and Industrial Engineering, Kuwait University, Kuwait*

**Keywords:** Once-through, MSF System, Recirculation, Performance Ratio, Heat Transfer, Stages, Condenser, Flow Sheet Development, Maintenance Design Features, Component Design, Material, Energy Comparison, Cost Estimation, Steam Supply, Desalting Plant, Co-generation Turbine

### Contents

1. Introduction
2. Once-through MSF System
  - 2.1 Single-stage Flash System
  - 2.2 Two-stage Flash System
  - 2.3 Multistage ( $n$ -stage) systems
3. Recirculation MSF System
  - 3.1 Recirculation arrangements
  - 3.2 Thermal Analysis of the Recirculation MSF System
  - 3.3 The Recirculation to Distillate Ratio  $R/D$
  - 3.4 Terminal Temperature Difference
4. Performance Ratio
5. Heat Transfer Area of the Stages Condenser
6. Flow Sheet Development
7. Maintenance Design Features
  - 7.1 Operating Temperature
  - 7.2 Flashing Brine Flow and Vapor Release Velocity
    - 7.2.1 Stage Width
    - 7.2.2 Stage Length
    - 7.2.3 Vapor Velocity and Stage Area
  - 7.3 Gain Ratio or Performance ratio
  - 7.4 Rated Capacity
  - 7.5 Number of Stages  $n$
  - 7.6 Temperature Profile
    - 7.6.1 Temperature Losses  $\delta t_{r\ell}$
    - 7.6.2 The Stage Temperature Approach  $\delta t_c$
  - 7.7 Stage Efficiency  $\eta_i$
  - 7.8 Deaeration
  - 7.9 Dearators
  - 7.10 Venting System
  - 7.11 Brine Level
  - 7.12 Concentration Ratio
  - 7.13 Plant Control and Instrumentation
    - 7.13.1 Top Brine Temperature
    - 7.13.2 Cooling Seawater Temperatures
    - 7.13.3 Last Stage Brine Level

#### 7.13.4 pH Control

### 8. Component Design and Material

#### 8.1 Evaporator Stage

#### 8.2 Interstage Control Devices

##### 8.2.1 Sluice Gates

##### 8.2.2 Box Type Orifice

##### 8.2.3 Interstage Pressure Drop

#### 8.3 Condensers Design

##### 8.3.1 Heat Transfer Relations

##### 8.3.2 Condensing Heat Transfer Coefficient ( $h_c$ )

##### 8.3.3 Brine Side-forced Convection Coefficient ( $h$ )

##### 8.3.4 Thermal Resistance of Walls

##### 8.3.5 The Fouling Resistance ( $r_f$ )

##### 8.3.6 Effect of Non-condensable Gases

##### 8.3.7 Condenser Materials

##### 8.3.8 Waterboxes

#### 8.4 Demisters

#### 8.5 Product Water Troughs

#### 8.6 Pumps

##### 8.6.1 A Typical Kuwaiti Plant

### 9. Rational Basis for Energy Comparison

#### 9.1 Specific Mechanical Work Consumption

### 10. Cost Estimation

#### 10.1 Energy Requirements for an MSF System

#### 10.2 Direct Boiler Driven MSF System

### 11. MSF Steam Supply to an MSF Desalting Plant from a Co-generation Turbine

#### 11.1 The Rating of Dual-purpose Power/Desalting Plants

##### 11.1.1 Rating of Single-purpose Power Plants

### 12. Reference Dual-purpose Power/Desalination Plant

#### 12.1 Energy Charged to Desalted Water by Different Allocation

##### 12.1.1 Method A: All Benefits of Dual-purpose Plants are Given to Power Production

##### 12.1.2 Method B: All Benefits are Given to the Desalting Process

##### 12.1.3 Method C: Available Energy Method

##### 12.1.4 Method D: Energy Allocated by Work Loss due to Extraction of Steam to Desalter

### 13. Conclusion

### Glossary

### Bibliography

## Process Description

### 1. Introduction

In a multieffect (ME) desalination system the vapor forming the product is generated by (a) boiling in the effects and (b) flashing between the effects due to the pressure drops between these effects.

The percentages of vapor produced in a typical ME system by boiling ( $m_b$ ) and by

flashing ( $m_f$ ) are 80 per cent and 20 per cent, respectively. The increase of feed to distillate ratio  $F/D$  increases the flashing to boiling ratio  $m_f/m_b$  and this requires an increase of feed pre-heaters and decreases the effects of boiling heat transfer areas. The limit to this procedure is to increase  $F/D$  to the extent that the required vapor is produced by flashing only, the boiling heat transfer surface in each effect is completely eliminated, and the feed heaters type condenser surface areas are increased to condense all vapor released. The first large desalting unit using this limiting case, called a multistage flash (MSF) system, was built in Kuwait by Westinghouse Company in 1957 to desalt 0.5 mgal day<sup>-1</sup> with four effects (called stages here) and 3.3 performance ratio (PR). The design of the unit was based on ME system analysis (presented earlier) with a PR close to but smaller than the number of effects (stages here).

Silver filed a patent (British Patent Application No. 829820, September 1957) for a MSF process with different analysis than the ME analysis in some respects.

The PR does not explicitly depend on the number of stages  $n$ .

The number of stages  $n$  in an integer number greater than at least twice the required PR. (In practice, the number of stages  $n$  is in the range of three times the PR). In 1958 Silver designed the first two units based on his patent. One unit was installed in Kuwait to produce 4550 m<sup>3</sup> day<sup>-1</sup> (1 mgal day<sup>-1</sup>) and has 24 stages and a PR of 5.8. The second unit has 40 stages producing 2775 m<sup>3</sup> day<sup>-1</sup> (0.5 mgal day<sup>-1</sup>) and has a PR of 10.5. Both units were commissioned with success in 1960. The dramatic increase in PR (compared to ME systems at that time) and the simplicity of the structure over the ME system have made MSF desalting systems the most used method for desalting seawater in large quantities since 1960. Since that time, individual units and plant capacities have continued to increase. Examples of the units and plant capacities in Kuwait are given in Table 1. In 1985, more than 80 per cent of the desalted seawater was produced by MSF plants.

	<i>Brine heater</i>	<i>Heat recover stage</i>		<i>Heat rejection stage</i>
		<i>First and second</i>	<i>All other stages</i>	
<i>Clean heat transfer coefficient (kW m<sup>-2</sup> C<sup>-1</sup>)</i>	4.57	3.58	4.92	4
<i>Design heat transfer Fouling factor (kW m<sup>-2</sup> C<sup>-1</sup>)</i>	2.07	2.33	2.83	2.25
<i>LMTD</i>	0.000263	0.000149	0.000149	0.000194
<i>When clean</i>	4.23	2.21	1.82	1.8
<i>At design point</i>	12.05	3.41	3.16	3.99
<i>Velocity (m s<sup>-1</sup>)</i>	2.13	1.98	1.98	2.08
<i>Material</i>	70/30 Cu-Ni	70/30 Cu-Ni	Al-brass	70/30 Cu-Ni
<i>n (efficiency)</i>				
<i>Area (m<sup>2</sup> per stage)</i>	0.99	0.99	0.99	0.98
<i>Number in stage</i>	3594	3676.5	3676	3148
<i>Tube dimensions</i>	1367	1451	1451	1588
<i>OD (mm)</i>	43.8	43.8	43.8	3.42
<i>length (m)</i>	18.84	18.84	18.84	18.84

Table 1. Data on typical 6 mgal day<sup>-1</sup> plants operating at  $T_o = 90.54^\circ\text{C}$

There are two possible types of MSF system: the once-through and recirculation MSF systems. The recirculation MSF system is the most widely used and appears superior to the once-through system in energy consumption. The once through system loses too much heat with brine rejection. The next sections consider both MSF systems.

## 2. Once-through MSF system

### 2.1 Single-stage Flash System

The once-through MSF represents the limiting case of the ME system when the feed flow rate is increased to the extent that the vapor is generated by flashing only and the boiling heat transfer surface is entirely omitted. The flash vapor is condensed on the feed heater-type condensers.

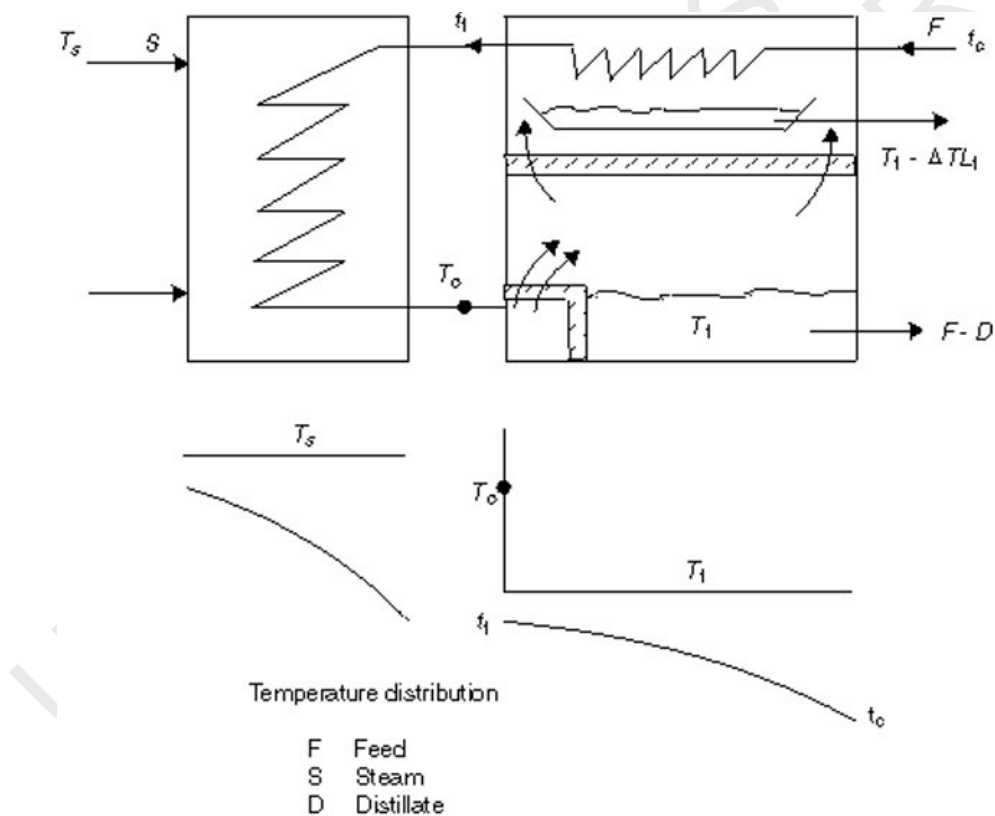

Figure 1. Single-stage flashing desalting system.

In a single-stage flash desalting system (Figure 1), the feed  $F$ , after pre-treatment, is pre-heated from  $t_c$  to  $t_1$  in the condenser tubes. It is then heated in the brine heater (called heat input section, HIS) to temperature  $T_o$  by condensing the supply steam  $S$  (main energy source). The feed, leaving the brine heater at temperature  $T_o$  and pressure  $P_o$ , enters the first flashing chamber (or stage) kept at  $P_1$  of saturation temperature  $T_1 < T_o$ . The feed becomes unstable and part of it is spontaneously vaporized (i.e. flashed in order to reach stability by dropping its temperature to  $T_1$ ). The vapor released by

flashing flows upward through demisters (to separate entrained liquid brine) to the condenser tubes in the upper portion of the chamber. The vapor condenses there and forms the product. The heat released by vapor condensation is gained (or recovered) by the heated feed. The temperature of the flashed vapor (from brine at  $T_1$ ) suffers some losses  $\Delta TL$  due to non-equilibrium, boiling point elevation, and pressure drops through the demister and condenser tubes. The following energy balances can be carried out by assuming the following.

(a) Constant and average specific heat  $C$  for the feed  $F$ , distillate  $D$ , and brine  $B$ , streams and constant and average latent heat value  $L$  for condensing vapour and supply steam.

(b) A completely insulated stage.

(i) For the condenser tubes

$$FC(t_1 - t_c) = DL \quad (1)$$

(ii) For flashing brine

$$FC(T_o - T_1) = DL \quad (2)$$

(iii) For the brine heater

$$Q = SL = FC(T_o - t_1) \quad (3)$$

where  $Q$  is the heat input rate ( $\text{kJ s}^{-1}$ ) and  $S$  is the steam flow rate assumed to be supplied at saturated vapor condition and leaves at saturated liquid condition.

For the whole desalting unit

$$FCt_c + SL \cong BCT_1 + DCT_{V1} \quad (4)$$

Since

$$F = B + D$$

and

$$T_{V1} = T_1 - \Delta TL$$

then

$$SL \cong FC(T_1 - t_c)$$

Equations (1), (2), and (4) give

$$t_1 - t_c = T_o - T_1$$

$$\frac{D}{S} = \frac{t_1 - t_c}{T_1 - t_c} < 1 \quad (5)$$

$$PR = \frac{2330D}{SL} < 1 \quad (6)$$

$$\frac{F}{D} = \frac{L}{C(T_o - T_1)} = \frac{L}{C(t_1 - t_c)} \quad (7)$$

A typical example of a single-stage MSF system where  $T_o = 90^\circ\text{C}$  (top brine temperature, TBT),  $t_c = 30^\circ\text{C}$  (seawater temperature), and temperature approach of the condenser  $T_1 - t_1 = 4.2^\circ\text{C}$  would give  $T_o - t_c = 60^\circ\text{C}$ ,  $t_1 = 57.9^\circ\text{C}$ ,  $T_1 = 62.1^\circ\text{C}$ ,  $D/S = 0.875$ , and  $F/D = 19.9$  ( $L$  is assumed equal to  $2330 \text{ kJ kg}^{-1}$ ).

The value of  $F/D$  ( $=19.9$ ) is large compared to  $F/D$  ( $=2.5$ ) for a single-effect or ME system when the feed total dissolved solids (TDS) =  $42000 \text{ p.p.m.}$  and brine blowdown  $TDS = 70\,000 \text{ p.p.m.}$

The areas of heat transfer surface for both the brine heater and condenser heat exchangers can be determined by equating the thermal load of each exchanger with the overall heat transfer coefficient  $U$ , multiplied by the surface area multiplied by the effective temperature (LMTD). For the brine heater (with subscript  $b$  for the parameters involved)

$$SL = U_b A_b (\text{LMTD})_b \quad (8)$$

where

$$(\text{LMTD})_b = \frac{(T_s - t_1) - (T_s - T_o)}{\ln(T_s - t_1)/(T_s - T_o)} \quad (9)$$

For the condenser (with subscript  $c$ )

$$DL = U_c A_c (\text{LMTD}) \quad (10)$$

$$(\text{LMTD})_c = \frac{(T_{v1} - t_c) - (T_{v1} - t_1)}{\ln \frac{T_{v1} - t_c}{T_{v1} - t_1}} \quad (11)$$

Recalling  $D/S = (t_1 - t_c)/(T_1 - t_c)$  and  $T_{v1} = T_1 - \Delta TL$ , the total specific area  $A_t/D = (A_b + A_c)/D$  is expressed by

$$\frac{A_t}{D} = \frac{T_1 - t_c}{t_1 - t_c} \frac{L}{U_b(T_o - t_1)} \ln \frac{T_s - t_1}{T_s - T_o} + \frac{L}{U_c(t_1 - t_c)} \ln \frac{T_1 - \Delta T_L - t_c}{T_1 - \Delta T_L - t_1} \quad (12)$$

The typical example mentioned earlier, with  $T_s = 100^\circ\text{C}$ ,  $T_o = 90^\circ\text{C}$ ,  $T_1 = 62^\circ\text{C}$ ,  $t_c = 30^\circ\text{C}$ ,  $t_1 = 58^\circ\text{C}$ ,  $\Delta T_L = 1.2^\circ\text{C}$  and by assuming  $U_b = 3 \text{ kW m}^{-2} \text{ C}^{-1}$  and  $U_c = 2.5 \text{ kW m}^{-2} \text{ C}^{-1}$  has a specific total area  $A_t/D = 108.74 \text{ m}^2 \text{ kg}^{-1} \text{ s}^{-1}$ .

### 2.2 Two-stage Flash System

Now a two-stage flash desalting system can be considered, as shown in Figure 2. The feed  $F$  entering the second stage condenser tubes at  $t_c$  is successively pre-heated to  $t_2$  and to  $t_1$  in the second and first stage condensers, respectively, before it enters the brine heater. The supply steam  $S$  raises the temperature of the feed in the brine heater from  $t_1$  to  $T_o$  before it enters the first stage as flashing brine which is kept at pressure  $P_1$  (of saturation temperature  $T_1 < T_o$ ).

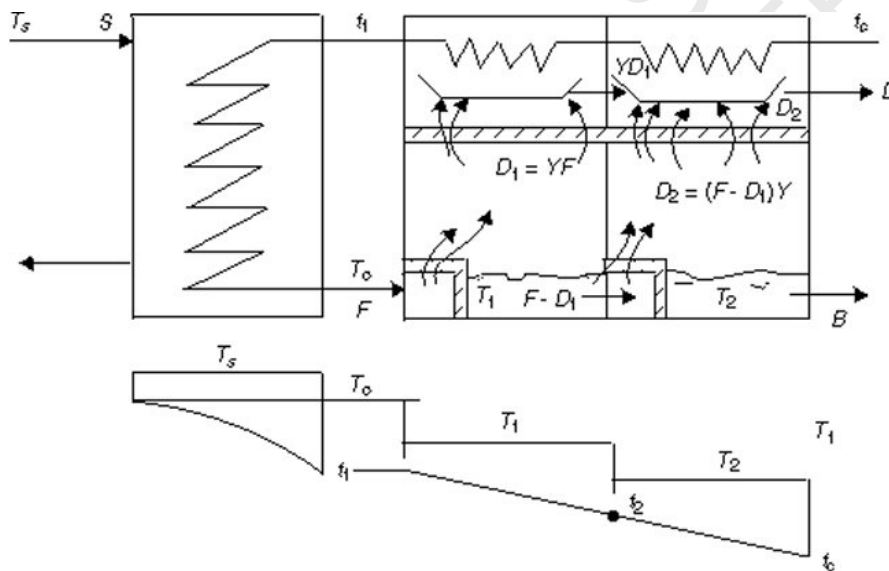

Figure 2. Two-stage once through MSF system.

The vapor generated in the first stage  $D_1$  (due to the pressure drop of the flashing brine) is condensed on the outer surface of this stage condenser tubes and, thus, raises the temperature of the feed circulating in this condenser from  $t_2$  to  $t_1$ . The unflashed brine ( $B_1 = F - D_1$ ) and the formed distillate  $D_1$  proceed to the second stage kept at pressure  $P_2$  of saturation temperature  $T_2 < T_1$ . Again both flashing brine and distillate suffer a pressure drop, partially evaporated by flashing and their temperatures drop to the second stage saturation temperature. The vapor generated in the second stage is condensed on these stage condenser tubes and heats the feed flowing in the condenser from  $t_c$  to  $t_2$ . The unflashed brine ( $B_2 = F - D_1 - D_2$ ) leaves the second stage as brine blowdown at  $T_2$ . The term  $D_2$  represents the vapor evaporated (flashed) from the flashing brine in the second stage only. The mass and energy balances for the two-stage flash desalting system give the following.

Brine heater

$$SL = FC(T_o - t_1)$$

Flashing brine entering the first stage

$$D_1L = FC(T_o - T_1)$$

First stage condenser tubes

$$D_1L = FC(t_1 - t_2) = FC\Delta t$$

where  $\Delta t = t_1 - t_2$

Second stage flashing brine

$$D_2L = (F - D_1)C(T_1 - T_2)$$

or

$$D_2 = (F - D_1)C\Delta T / L$$

where  $\Delta T = T_1 - T_2$  and  $D_2$  is the vapor released from flashing brine. Vapor flashed from distillate  $D$  entering the second stage is equal to

$$D_1C(T_{v1} - T_{v2})/L = D_1C\Delta T / L$$

Accumulated vapor condensed on the second stage condenser tubes is equal to

$$D_2 + D_1C\Delta T / L = FC\Delta t / L$$

Second stage condenser

$$FC(t_2 - t_c) = FC(T_1 - T_2)$$

Overall system (assuming no heat losses)

$$SL = FC(T_2 - t_c)$$

The above equations give

$$T_o - t_1 = T_2 - t_c$$

$$T_o - T_1 = t_1 - t_2$$

$$T_1 - T_2 = t_2 - t_c = \Delta T$$



-  
-  
-

TO ACCESS ALL THE 98 PAGES OF THIS CHAPTER,  
Visit: <http://www.desware.net/DESWARE-SampleAllChapter.aspx>

### Bibliography

- Al-Zubaidi A A (1987) Seawater desalination in Kuwait - a report on 33 years experience. *Desalination* **63**, 1-55.
- Barba D, Bogazzi D, German A and Tagliferrri (1980) Analysis of large desalination plants. *Desalination* **33**, 1-10.
- Birkett and Newton E H (1981) *Survey of Service Behavior of Large Evaporative Desalting Plants, PB82-1203 12*. Washington, DC: Office of Water Research and Technology.
- Darwish M A (1986) On the thermodynamics of dual purpose power-desalting plants, part I: using steam turbines. *Desalination* **64**, 151-167.
- Darwish M A (1987) Critical comparison between energy consumption in large capacity reverse osmosis (RO) and multistage flash (MSF) sea water desalting plants. *Desalination* **63**, 143-161.
- Darwish M A (1988) Cogeneration power-desalination plants. *Desalination* **69**, 27-46.
- Darwish M A (1991) Thermal analysis in MSF desalting systems. *Desalination* **85**, 59-79.
- Darwish M A (1995) Fuel cost charged to desalters in cogeneration power-desalination plants. *Heat Recovery Systems and CHP* **15**(4), 357-368.
- Darwish M A et al. (1987) Energy consumption and cost of different desalting systems. *Desalination* **64**, 83-96.
- Genthner K, Wangnick K, Bodendick F and Al Gobaisi D (1997) The next size generation of MSF evaporators, 100,000 m<sup>3</sup>/d L. (Thermal and Hydraulic Design Recommendation IDA Conference, Madrid, 1997).
- Hanbury T (1980) *A Short Course on Desalination Technology*. Jeddab, King Abdul Aziz University.
- Khan A H (1986) Desalination processes and multistage flash distillation practice. Amsterdam: Elsevier.
- Office of Saline Water report (OSW) , 1966 OSW N0.214 , Washington DC
- Office of Saline Water report (OSW) , 1967 OSW N0.315 , Washington DC
- Office of Saline Water report (OSW) , 1980 OSW N0.108 , Washington DC